

18/30(36) kV CV-SWA (CE Optional)*

IEC 60502-2 (3 CORE)

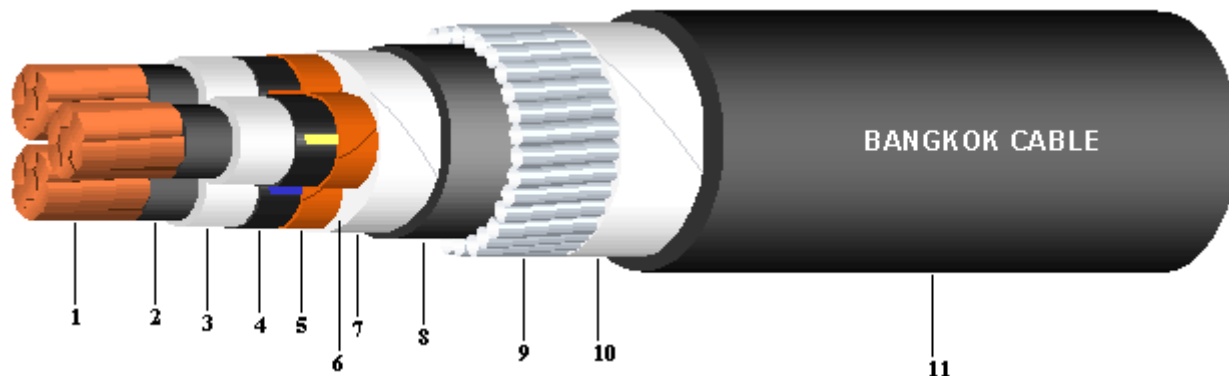

Construction :

1. Conductor : Compact round stranded annealed copper wires
2. Conductor screen : Semi-conductive Cross-linked polyethylene (XLPE) compound
3. Insulation : Cross-linked polyethylene (XLPE)
4. Insulation screen : Semi-conductive Cross-linked polyethylene (XLPE) compound
5. Metallic screen : Copper tape
6. Filler : Polypropylene (Non-hygroscopic material)
7. Binding tape : Polyester / Spunbond tape
8. Inner sheath : Polyvinyl chloride (PVC), (Optional : PE)*
9. Armour : Galvanized steel wires (Optional : Steel tape)
10. Binding tape : Polyester / Spunbond tape
11. Outer sheath : Polyvinyl chloride (PVC), (Optional : PE)*

Application :

For general purpose power distribution in dry and wet location, installation in exposed, in conduit or duct or direct burial in ground.

Size	Conductor		Insulation thickness nominal	Diameter over insulation (Approx.)	Inner Sheath thickness nominal	Galvanized steel wire diameter	Diameter over armour (Approx.)	Outer Sheath thickness nominal	Overall diameter (Approx.)	Maximum DC. Conductor resistance at 20°C	Current rating in air	Cable weight (Approx.)	Standard length
	Number of wires (Min.)	Diameter (Approx.)											
mm ²		mm	mm	mm.	mm	mm	mm.	mm	mm	ohm/km	A	kg/km	m
50	6	8.33	8.0	26.1	1.8	3.15	71.5	3.4	82	0.387	215	10050	200
70	12	9.73	8.0	27.5	1.9	3.15	74.5	3.5	86	0.268	265	11205	200
95	15	11.43	8.0	29.2	1.9	3.15	78.0	3.7	90	0.193	320	12675	150
120	18	12.95	8.0	30.7	2.0	3.15	81.5	3.8	94	0.153	365	14075	150
150	18	14.27	8.0	32.1	2.0	3.15	84.5	3.9	97	0.124	415	15355	150
185	30	15.98	8.0	33.8	2.1	3.15	88.5	4.0	101	0.0991	470	17170	100
240	34	18.47	8.0	36.9	2.2	3.15	95.5	4.2	109	0.0754	545	20175	100